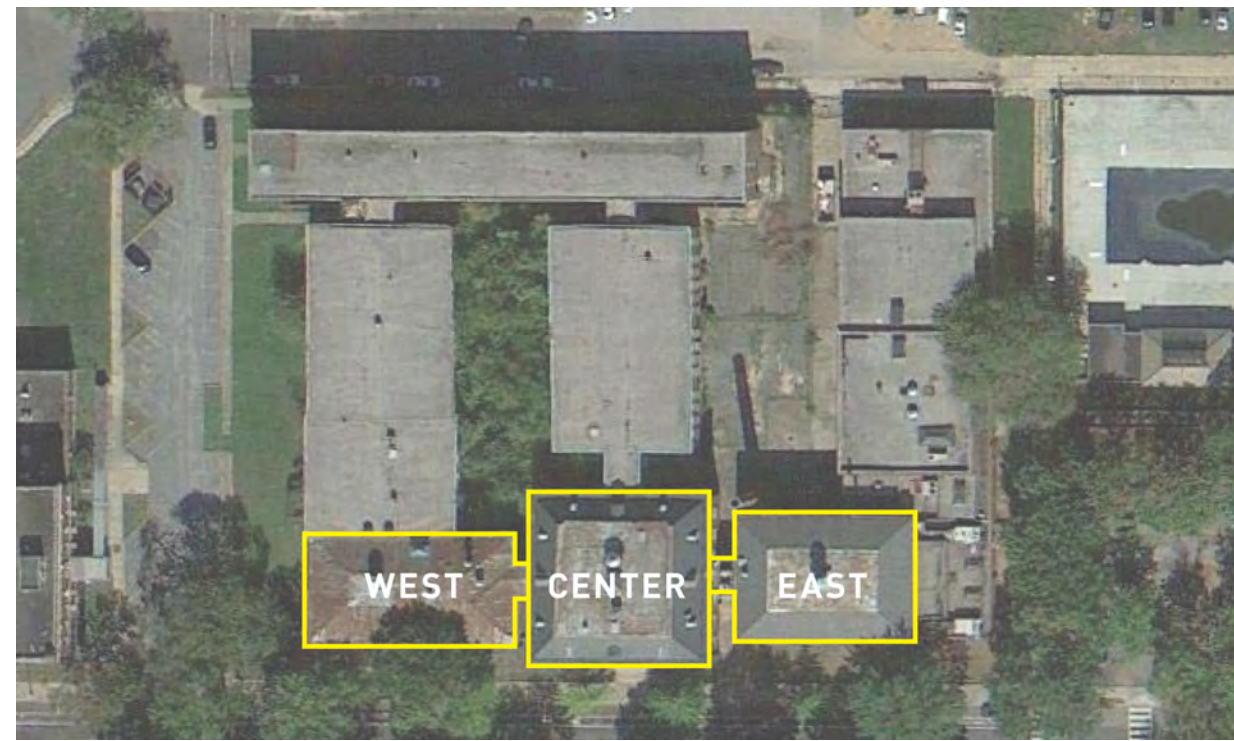
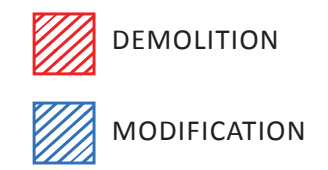
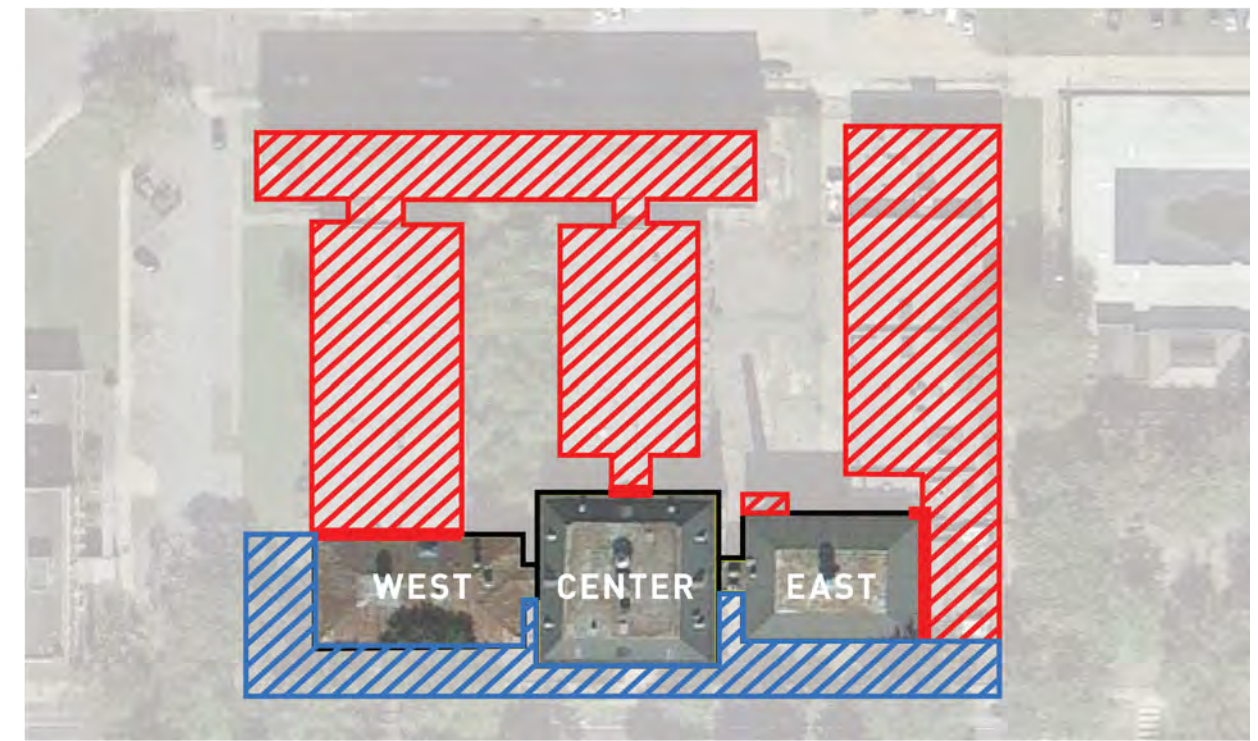



EXHIBIT FROM THE HISTORIC REHABILITATION TREATMENT REPORT PREPARED BY EHT TRACERIES DATED JULY 2011



RETAINED HERITAGE BUILDINGS



PROPOSED DEMOLITION AND FACADE MODIFICATION LOCATIONS



CENTRAL BUILDING PHOTOGRAPH (1908)- ROLLED CURB



PHOTOGRAPH FROM 1960- SUMMER SCHOOL ARCHIVES



PROPOSED SOUTH ELEVATION



SOUTH ELEVATION (EXISTING CONDITIONS)

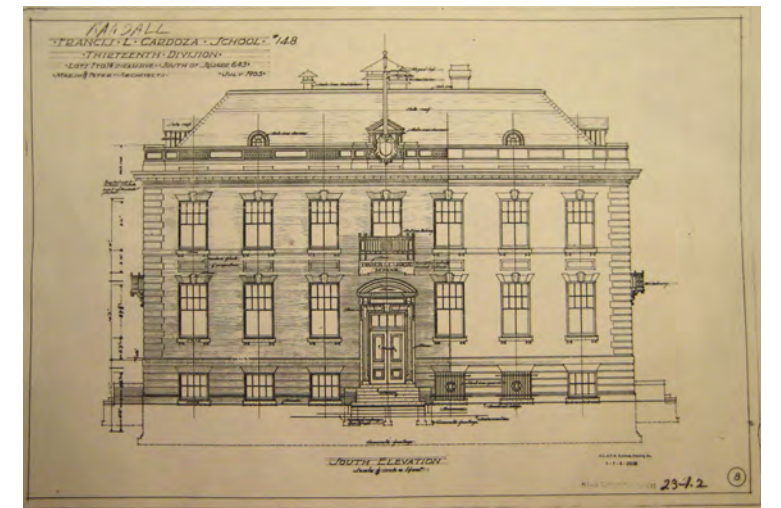

SOUTH ELEVATION - ORIGINAL DRAWING (1905)

CENTRAL BUILDING - SOUTH ELEVATION (PROPOSED)

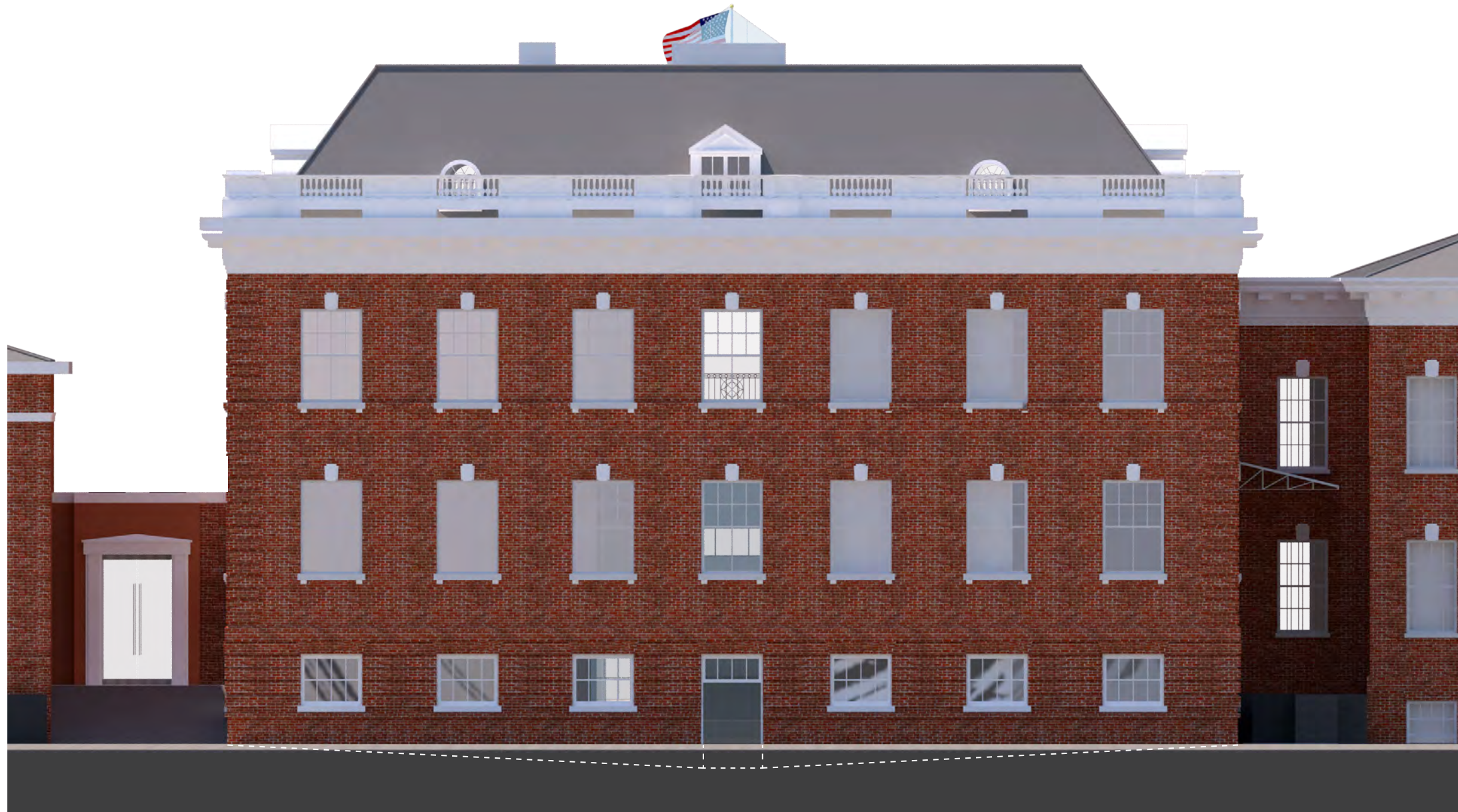

PROPOSED NORTH ELEVATION

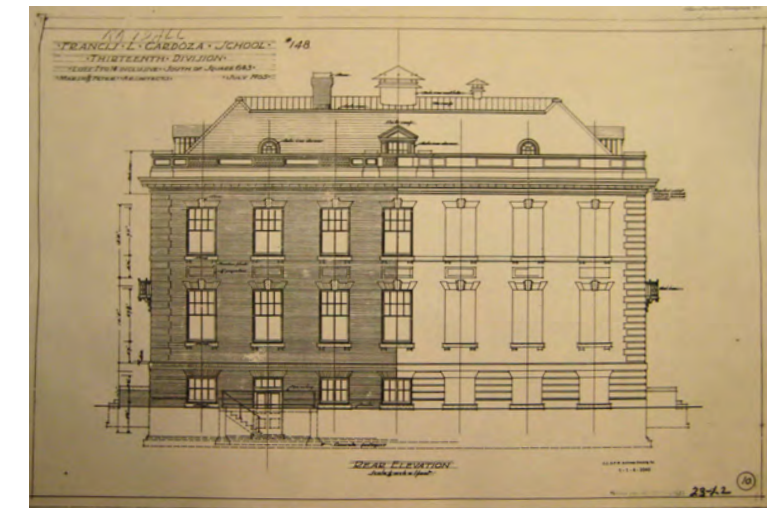

NORTH ELEVATION - ORIGINAL DRAWING (1905)

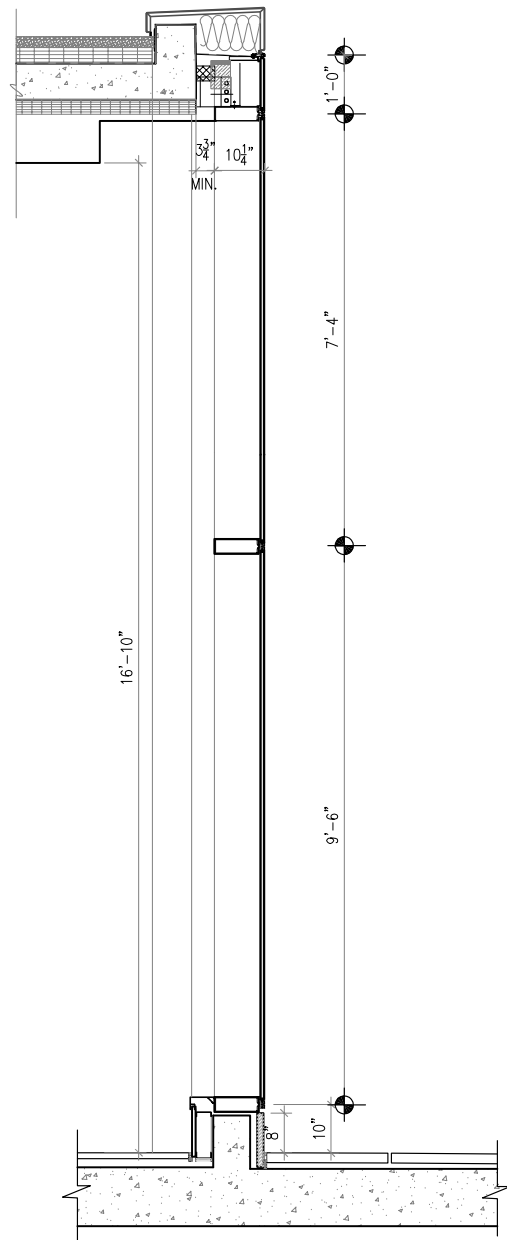

GLAZING WALL SECTION
SCALE: 1/4" = 1'



ENTRY PRECEDENT: BOWDOIN COLLEGE ART MUSEUM

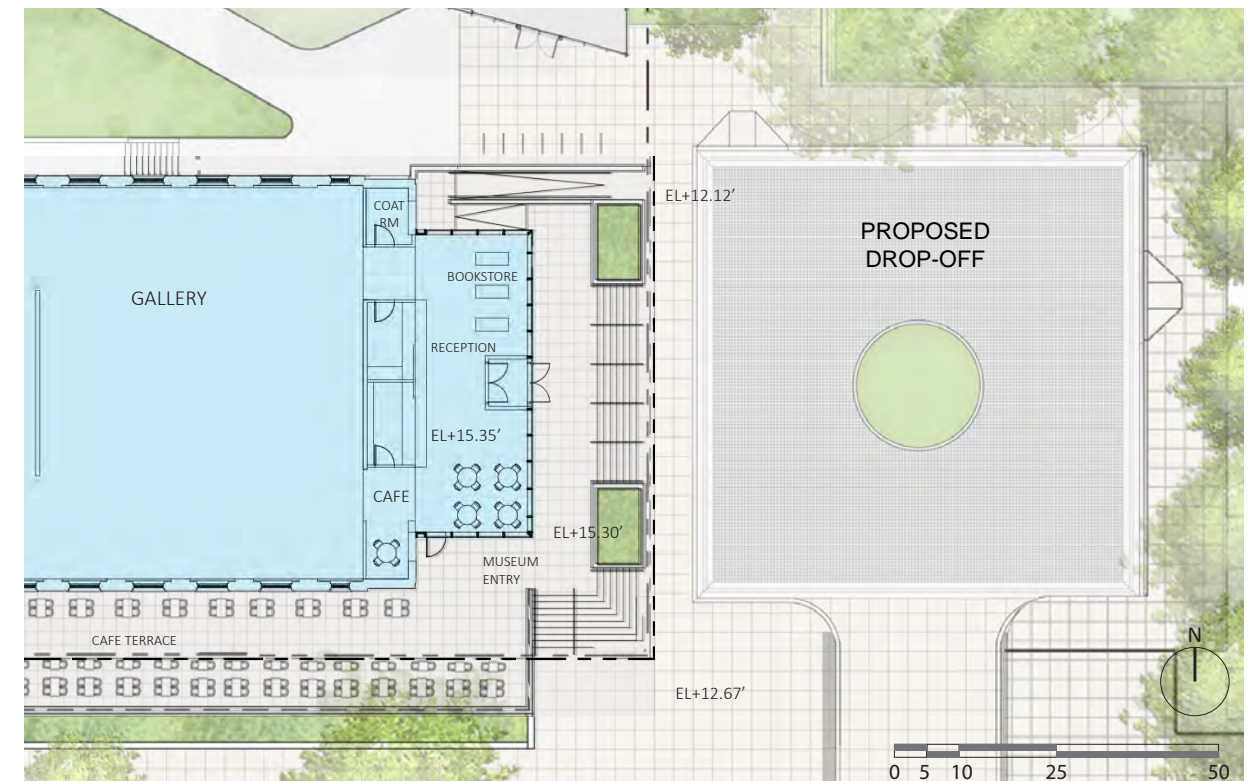

PROPOSED MUSEUM ENTRY PLAN

EAST WING - ENTRY PLAN AND DETAILS
RANDALL SCHOOL | PUD Modification





SOUTH ELEVATION



WEST ELEVATION



HISTORIC BUILDING LOADING

WEST WING - SOUTH AND WEST ELEVATIONS



WEST WING NORTH ELEVATION

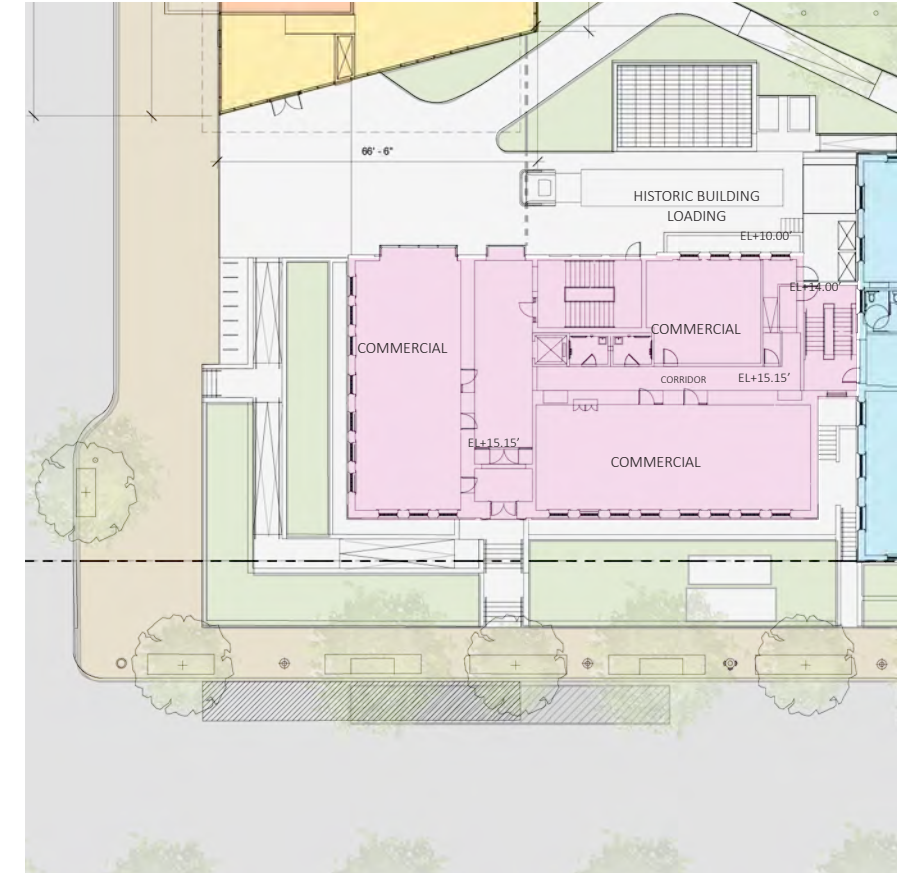

WEST WING FLOOR PLAN



WEST WING NORTH ELEVATION